

General Description



The BDE-MP2652R7A is a multiprotocol 2.4-GHz wireless module supporting Thread, Zigbee®, Matter, Bluetooth® 5.0 Low Energy, IEEE 802.15.4g, IPv6-enabled smart objects (6LoWPAN), TI 15.4-Stack (2.4 GHz), and concurrent multiprotocol through a Dynamic Multiprotocol Manager (DMM) driver. The module is based on an Arm® Cortex® M4F main processor and optimized for low-power wireless communication and advanced sensing in grid infrastructure, building automation, retail automation, personal electronics and medical applications.

The BDE-MP2652R7A has a software defined radio powered by an Arm® Cortex® M0, which allows support for multiple physical layers and RF standards. PHY and frequency switching can be done runtime through a dynamic multiprotocol manager (DMM) driver. The module supports +5 dBm TX at 9.7 mA in the 2.4-GHz band. It has a receive sensitivity of -103 dBm for 125-kbps Bluetooth® Low Energy Coded PHY.

The module has a low sleep current of 0.9 μ A with RTC and 144KB RAM retention. In addition to the main Cortex® M4F processor, the device also has an autonomous ultra-low power Sensor Controller CPU with fast wake-up capability. As an example, the sensor controller is capable of 1-Hz ADC sampling at 1- μ A system current.

The module has Low SER (Soft Error Rate) FIT (Failure-in-time) for long operational lifetime. Always-on SRAM parity minimizes risk for corruption due to potential radiation events. Consistent with many customers' 10 to 15 years or longer life cycle requirements.

BDE-MP2652R7A integrates all required system-level hardware components including clocks, passives, and PCB antenna into a QFM package for easy assembly and low-cost PCB design.

Key Features

- Wireless microcontroller
 - Powerful 48-MHz Arm® Cortex®-M4F processor
 - 704KB flash program memory
 - 256KB of ROM for protocols and library functions
 - 8KB of cache SRAM
 - 144KB of ultra-low leakage SRAM with parity for high-reliability operation
 - Dynamic multiprotocol manager (DMM) driver
 - Programmable radio includes support for 2-(G)FSK, 4-(G)FSK, MSK, Bluetooth® 5.0 Low Energy, IEEE 802.15.4 PHY and MAC
 - Supports over-the-air upgrade (OTA)
- Ultra-low power sensor controller
 - Autonomous MCU with 4KB of SRAM
 - Sample, store, and process sensor data
 - Fast wake-up for low-power operation
 - Software defined peripherals, capacitive touch, flow meter, LCD
- Low power consumption
 - MCU consumption:
 - ◇ 3.10 mA active mode, CoreMark
 - ◇ 65 μ A/MHz running CoreMark
 - ◇ 0.9 μ A standby mode, RTC, 144KB RAM
 - ◇ 0.1 μ A shutdown mode, wake-up on pin

- Ultra low-power sensor controller consumption:
 - ✧ 29.2 μ A in 2 MHz mode
 - ✧ 799 μ A in 24 MHz mode
- Radio Consumption:
 - ✧ 6.4 mA RX
 - ✧ 7.3 mA TX at 0 dBm
 - ✧ 9.7 mA TX at +5 dBm
- Wireless protocol support
 - Thread, Zigbee®, Matter
 - Bluetooth® 5.0 Low Energy
 - SimpleLink™ TI 15.4-stack
 - 6LoWPAN
 - Proprietary systems
- High performance radio
 - -103 dBm for Bluetooth® Low Energy 125-kbps
 - Output power up to +5 dBm with temperature compensation
- Regulatory compliance (On-going)
 - FCC
 - IC
 - CE-RED
 - Bluetooth SIG
- MCU peripherals
 - Digital peripherals can be routed to any GPIO
- Four 32-bit or eight 16-bit general-purpose timers
- 12-bit ADC, 200 kSamples/s, 8 channels
- 8-bit DAC
- Two comparators
- Programmable current source
- Two UART, two SSI, I2C, I2S
- Real-time clock (RTC)
- Integrated temperature and battery monitor
- Security enablers
 - AES 128- and 256-bit cryptographic accelerator
 - ECC and RSA public key hardware accelerator
 - SHA2 Accelerator (full suite up to SHA-512)
 - True random number generator (TRNG)
- Operating range
 - On-chip buck DC/DC converter
 - 1.8-V to 3.8-V single supply voltage
 - -40 to +85°C
 - -40 to -105°C (BDE-MP2652R7A-IN)
- Antenna: PCB antenna
- Package
 - Dimension: 22.95 mm x 15 mm x 2.15 mm
 - QFM-36 (31 GPIOs)
 - RoHS-compliant package

Applications

- 2400 to 2480 MHz ISM and SRD systems with down to 4 kHz of receive bandwidth
- Building automation
 - Building security systems – motion detector, electronic smart lock, door and window sensor, garage door system, gateway
 - HVAC – thermostat, wireless environmental sensor, HVAC system controller, gateway
 - Fire safety system – smoke and heat detector, fire alarm control panel (FACP)
 - Video surveillance – IP network camera
 - Elevators and escalators – elevator main control panel for elevators and escalators
- Industrial transport – asset tracking
- Factory automation and control
- Medical
- Electronic point of sale (EPOS) – Electronic Shelf Label (ESL)
- Communication equipment
 - Wired networking – wireless LAN or Wi-Fi access points, edge router, small business router
- Personal electronics
 - Home theater & entertainment – smart speakers, smart display, set-top box
 - Wearables (non-medical) – smart trackers, smart clothing

Contents

General Description	1
Key Features	1
Applications	2
Contents	3
1. References	4
2. Block Diagram	5
3. Terminal Configuration and Functions	6
3.1 Pin Diagram	6
3.2 Pin Attributes and Pin Multiplexing	6
4. Specifications	8
4.1 Absolute Maximum Ratings	8
4.2 Recommended Operating Conditions	8
5. Mechanical Specifications	9
5.1 Dimensions	9
5.2 PCB Footprint	10
5.3 Marking	10
6. Typical Reflow Profile	11
7. Ordering Information	12
8. Revision History	12

1. References

- [1] CC2652R7 resources: <https://www.ti.com/product/CC2652R7>

2. Block Diagram

BDE-MP2652R7A module is based on the Texas Instruments CC2652R7 single chip wireless MCU. With integrated clocks, other required passives and antenna, it allows faster time to market at reduced development cost.

The module, as seen in Figure 2-1, comprises of:

- 48-MHz XTAL
- 32.768-kHz XTAL
- Power inductors and capacitors
- Pull-up resistor
- Passive balun filter
- Decoupling capacitors
- Matching circuit PCB trace antenna

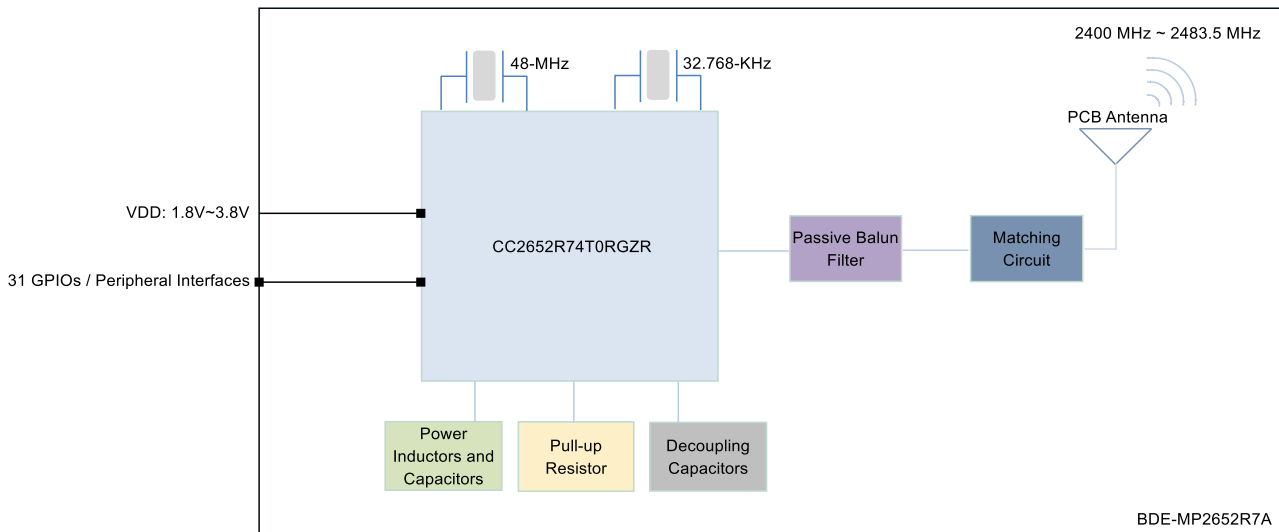

Figure 2-1. BDE-MP2652R7A Module Block Diagram

3. Terminal Configuration and Functions

3.1 Pin Diagram

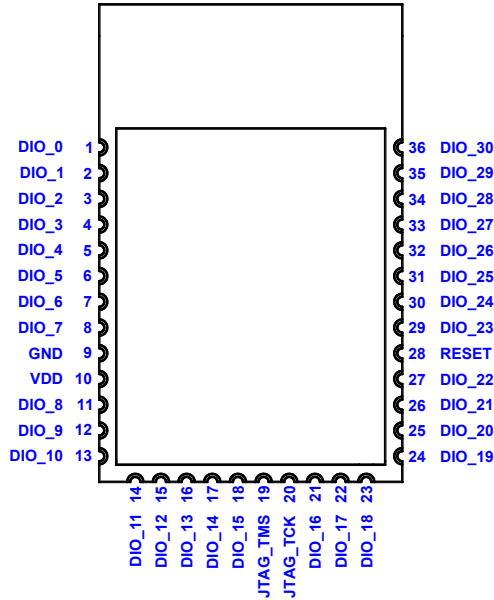

Figure 3-1. Pin Diagram (Top View)

3.2 Pin Attributes and Pin Multiplexing

Table 3-1 describes the definitions of the pins of the module.

Table 3-1. Pin Description ⁽¹⁾

Module Pin #	Pin Name	Type	Description
1	DIO_0	I/O	GPIO
2	DIO_1	I/O	GPIO
3	DIO_2	I/O	GPIO
4	DIO_3	I/O	GPIO
5	DIO_4	I/O	GPIO
6	DIO_5	I/O	GPIO, high-drive capability
7	DIO_6	I/O	GPIO, high-drive capability
8	DIO_7	I/O	GPIO, high-drive capability
9	GND	Ground	Power ground
10	VDD	Power	Power supply
11	DIO_8	I/O	GPIO
12	DIO_9	I/O	GPIO
13	DIO_10	I/O	GPIO
14	DIO_11	I/O	GPIO
15	DIO_12	I/O	GPIO
16	DIO_13	I/O	GPIO
17	DIO_14	I/O	GPIO
18	DIO_15	I/O	GPIO
19	JTAG_TMS	I/O	JTAG TMS, high-drive capability
20	JTAG_TCK	I	JTAG TCK
21	DIO_16	I/O	GPIO, JTAG_TDO, high-drive capability
22	DIO_17	I/O	GPIO, JTAG_TDI, high-drive capability

Module Pin #	Pin Name	Type	Description
23	DIO_18	I/O	GPIO
24	DIO_19	I/O	GPIO
25	DIO_20	I/O	GPIO
26	DIO_21	I/O	GPIO
27	DIO_22	I/O	GPIO
28	RESET	I	Reset, active-low, 100K ohm internal pull-up resistor
29	DIO_23	I/O	GPIO, analog capability
30	DIO_24	I/O	GPIO, analog capability
31	DIO_25	I/O	GPIO, analog capability
32	DIO_26	I/O	GPIO, analog capability
33	DIO_27	I/O	GPIO, analog capability
34	DIO_28	I/O	GPIO, analog capability
35	DIO_29	I/O	GPIO, analog capability
36	DIO_30	I/O	GPIO, analog capability

Note ⁽¹⁾: For more information, please refer to [CC2652R7](#) datasheet.

4. Specifications

4.1 Absolute Maximum Ratings

Stresses beyond those listed under Absolute Maximum Ratings may cause permanent damage to the device. These are stress ratings only, so functional operation of the device at these or any other conditions beyond those indicated in the operational sections of the specification are not implied. Exposure to Absolute Maximum Rating conditions for extended periods may affect device reliability.

PARAMETER	MIN	MAX	UNIT	Notes
VDD	-0.3	4.1	V	
Voltage on any digital pins	-0.3	$VDD+0.3 \leq 4.1$	V	
Voltage on ADC input	-0.3	VDDS	V	Voltage scaling enabled
	-0.3	1.49	V	Voltage scaling disabled, internal reference
	-0.3	$VDD/2.9$	V	Voltage scaling disabled, VDD as reference
Storage temperature	-40	125	°C	

4.2 Recommended Operating Conditions

PARAMETER	MIN	TYP	MAX	UNIT
VDDS	1.8	3.3	3.8	V
Operating temperature	-40	-	85	°C
Rising supply voltage slew rate	0		100	mV/us
Falling supply voltage slew rate	0		20	mV/us

5. Mechanical Specifications

5.1 Dimensions

The following pages include mechanical, footprint drawings, and marking information. This information is the most current data available for the designated devices. This data is subject to change without notice and revision of this document.

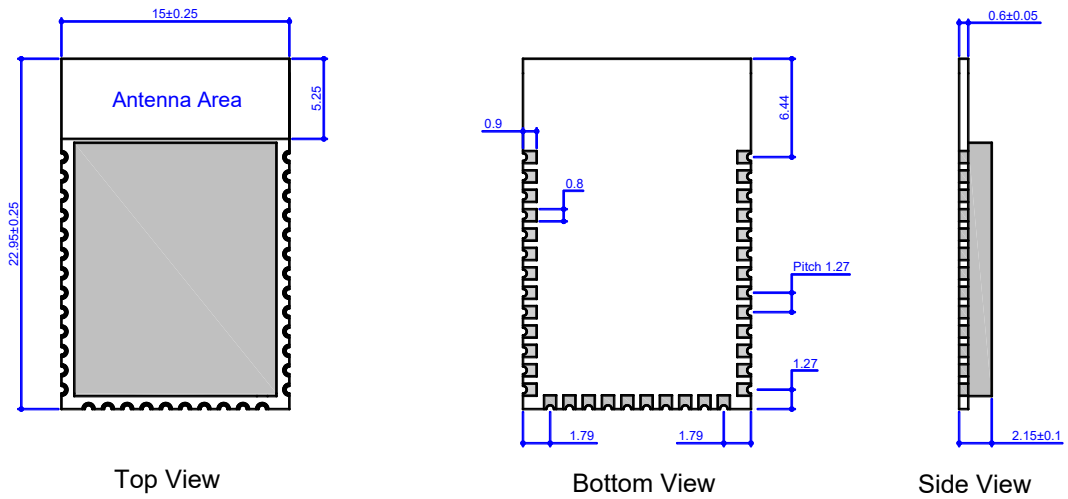
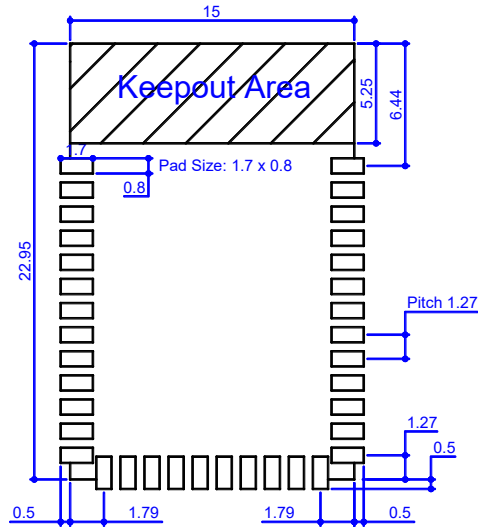

Fig 5-1. Mechanical Drawing

5.2 PCB Footprint



Note:

- 1. All dimensions are in millimeter;
- 2. Solder mask should be the same or 5% larger than the dimension of the pad;
- 3. Solder paste must be the same as the pin for all peripheral pads.

Fig 5-2. Module Footprint Top View

5.3 Marking



Fig 5-3. Module Marking

6. Typical Reflow Profile

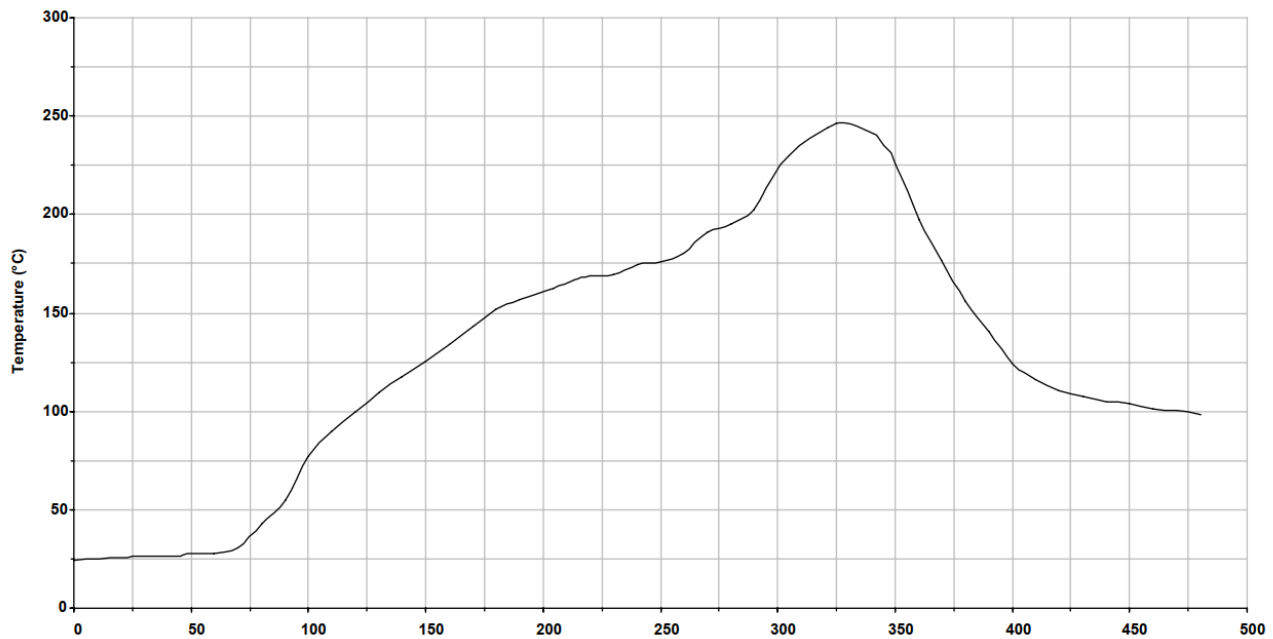

Figure 6-1. Typical Reflow Profile

Key features of the profile:

- Initial ramp = 1-2.5°C/sec to 175°C ±25°C equilibrium
- Equilibrium time = 60 to 180 seconds
- Ramp to maximum temperature (245°C) = 3°C/sec max.
- Time above liquidus temperature (217°C): 45-90 seconds
- Device absolute maximum reflow temperature: 260°C

7. Ordering Information

Part Number	Size (mm)	Core Chip	Operating Temperature	Shipping Form	MOQ
BDE-MP2652R7A	22.95 × 15 × 2.15	CC2652R7	-40 to +85°C	Tape & Reel	1K
BDE-MP2652R7A-IN	22.95 × 15 × 2.15	CC2652R7	-40 to +105°C	Tape & Reel	1K

8. Revision History

Revision	Date	Description
V1.0	25-September-2022	Initial Release

Contacts

BDE Technology Inc.

USA: 67 E Madison St, #1603A, Chicago, IL 60603, US

Tel: +1-312-379-9589

Website: <http://www.bdecomm.com>

Email: info@bdecomm.com

China: B2-403, 162 Science Avenue, Huangpu District, Guangzhou 510663, China

Tel: +86-20-28065335

Website: <http://www.bdecomm.com>

Email: shu@bdecomm.com