

General Description



BDE-BW3300NPxM2 is a 2.4-GHz Wi-Fi 6 wireless M.2 card based on TI's 10th generation connectivity combo chip CC3300 which is based upon proven technology and complements the TI integrated devices for connectivity portfolio. This module is ideal for use in cost sensitive embedded applications with a Linux or RTOS host running TCP/IP, where the peak throughput requirement is 50 Mbps maximum at the IP layer. BDE-BW3300NPxM2 could be the best choice for bringing the efficiency of Wi-Fi 6 to embedded device applications with a small PCB footprint and highly optimized bill of materials with lower cost. The module integrates a BDE module (BDE-BW3300NP1 or BDE-BW3300NP2) on board, and provides a PCI Express M.2 interface to user, which is 2230 Key-E M.2 interface. It is designed for ease of use and integration to the embedded systems.

This module has two variants described as follows:

- BDE-BW3300NP1M2, single antenna port with U.FL connector;
- BDE-BW3300NP2M2, dual antenna port with U.FL connector, supports antenna diversity.

Key Features

- Highly optimized Wi-Fi 6 system for low cost embedded IoT applications
- Seamless integration with TI Sitara™ MPU (Linux) / MCU+ (FreeRTOS) as well as other application processors
- 3-wire or 1-wire PTA for external coexistence with additional 2.4GHz radios (e.g. Thread or Zigbee)
- Multirole support e.g. STA and AP to connect directly with other Wi-Fi devices on different RF channels (Wi-Fi networks)
- Optional antenna diversity or selection (BDE-BW3300NP2M2)
- Operating temperature: -40°C to +85°C
- Wi-Fi 6®
 - MAC, Baseband and RF Transceiver with support for IEEE 802.11 a/b/g/n/ax Wi-Fi6
 - Medium access controller (MAC)
- Hardware-based encryption and decryption using supporting WPA2 and WPA3
- TWT and OFDMA for optimal embedded performance
- Application throughput up to 50 Mbps
- Supports 4-bit SDIO and SPI host interfaces
- Integrated 2.4G-Hz PA for complete wireless solution with up to +20dBm output power
- Security
 - Secured host interface
 - Firmware authentication
 - Anti-rollback protection
- Power Management
 - VDD_1V8: 1.62 V - 1.98 V
 - VDD_3V3: 2.1 V - 4.2 V
- Clock Source:
 - On board 40 MHz XTAL fast clock

- External 32.768-kHz slow clock by default
- Interface and Form Factor
 - PCI Express M.2 standard – 2230 Key-E
 - 22 mm x 30 mm x 2.8 mm
- Regulatory (In Progress)
 - FCC
 - IC
 - CE-RED

Applications

- Grid Infrastructure
 - Electricity Meter
 - String Inverter
 - Micro Inverter
 - Energy Storage Power Conversion System (PCS)
- Building and Home Automation
 - HVAC Controller
 - HVAC Gateway
 - Thermostat
 - Building Security Gateway
 - Garage door system
 - IP network camera/ Video doorbell
 - Wireless security camera
- Appliances
 - Refrigerator & freezer
 - Oven
 - Washer & dryer
 - Residential water heater & heating system
- Air purifier & humidifier
- Coffee machine
- Air conditioner indoor unit
- Vacuum robot
- Robotic lawn mower
- Medical
 - Infusion pump
 - Electronic hospital bed & bed control
 - Multiparameter patient monitor
 - Blood glucose monitor
 - Blood pressure monitor
 - CPAP machine
 - Telehealth systems
 - MRI
 - Ultrasound scanner
 - Ultrasound smart probe
 - Electric toothbrush
- Retail Automation and Payment

Contents

General Description.....	1
Key Features.....	1
Applications	3
Contents	4
1. References	5
2. Block Diagram	6
3. Terminal Configuration and Functions	7
3.1. Pin Diagram	7
3.2. Pin Attributes and Pin Multiplexing.....	7
4. Specifications	9
4.1. Absolute Maximum Ratings	9
4.2. ESD Ratings	9
4.3 Recommended Operating Conditions.....	9
5. Mechanical Specifications	10
5.1 Dimensions.....	10
5.1 U.FL Connector Specification	11
6. Reference Design.....	11
6.1 Block Diagram	11
6.2 Reference Schematic	12
6.3 Design Consideration	12
7. Ordering Information	12
8. Revision History	12
Important Notice and Disclaimer	13
Contact.....	13

1. References

1. CC3300 resources: <https://www.ti.com/product/CC3300>

2. Block Diagram

BDE-BW3300NPxM2 module is based on the TI's 10th generation connectivity combo chip CC3300.

The module, as seen in below diagram, comprises of:

- BDE-BW3300NPx module (BDE-BW3300NP1 or BDE-BW3300NP2)
- 3.3V to 1.8V LDO
- Level translator circuits
- Inverter Buffer (IRQ_WL)
- U.FL connectors
- Other passives

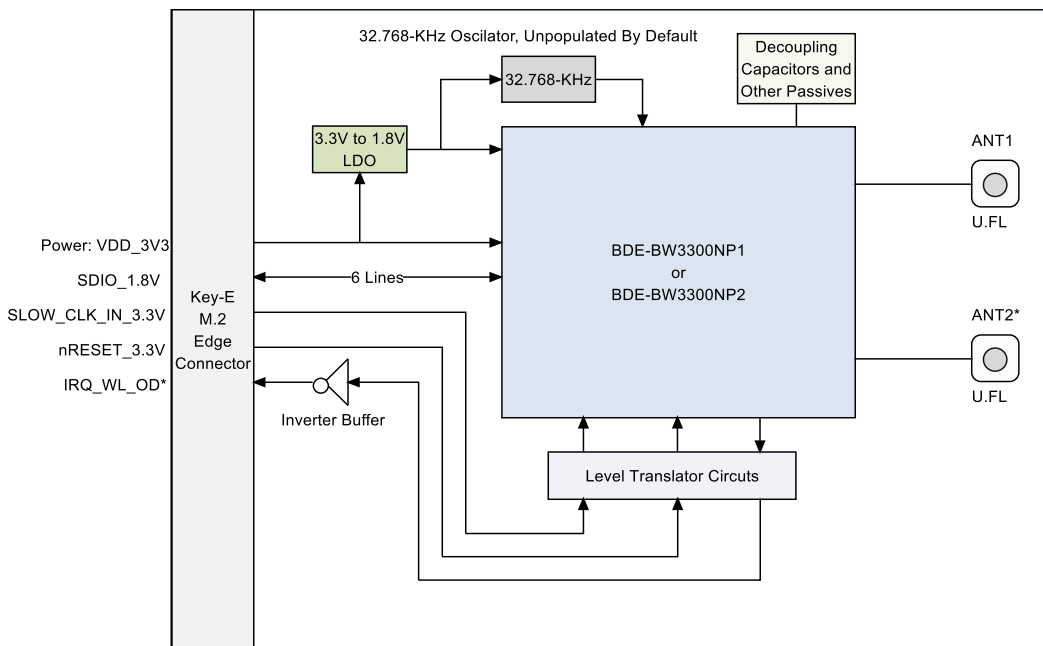

* ANT2 only applies to BDE-BW3300NP2M2 with Antenna Diversity Feature
 * IRQ_WL_OD is an open-drain output and has an inverter buffer to invert it

Figure 2-1. Block Diagram of BDE-BW3300NP1M2 or BDE-BW3300NP2M2

3. Terminal Configuration and Functions

3.1. Pin Diagram

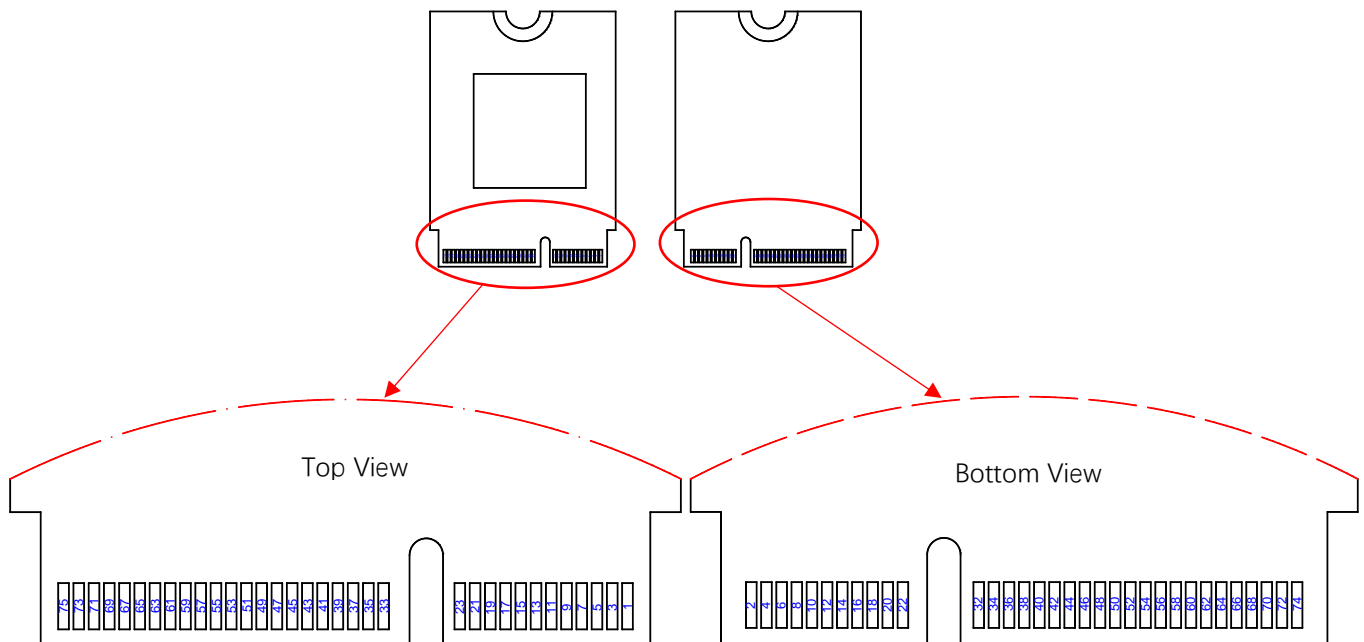

Figure 3-1. Pin Diagram of BDE-BW3300NPxM2

3.2. Pin Attributes and Pin Multiplexing

Table 3-1. Pin Description

Module Pin #	Pin Name	Type	Description
1	GND	Ground	Power ground
2	VDD_3V3	Power	3.3V power supply, 2.1V ~ 4.2V
3	NC	-	No connect
4	VDD_3V3	Power	3.3V power supply, 2.1V ~ 4.2V
5, 6	NC	-	No connect
7	GND	Ground	Power ground
8	NC	-	No connect
9	SDIO_CLK_1V8	I	SDIO_CLK_WL (SPI_CLK), 1.8V level, must be driven by host
10	NC	-	No connect
11	SDIO_CMD_1V8	I	SDIO_CMD_WL (SPI_DIN), 1.8V level
12	NC	-	No connect
13	SDIO_D0_1V8	I/O	SDIO_D0_WL (SPI_DOUT), 1.8V level
14	NC	-	No connect
15	SDIO_D1_1V8	I/O	SDIO_D1_WL, 1.8V level
16	NC	-	No connect
17	SDIO_D2_1V8	I/O	SDIO_D2_WL, 1.8V level
18	GND	Ground	Power ground
19	SDIO_D3_1V8	I/O	SDIO_D3_WL (SPI_CSX), 1.8V level
20	NC	-	No connect
21	IRQ_WL	O	IRQ_WL to host, open drain, need pull-up resistor to 1.8V or 3.3V depending on system choice, Falling edge trigger
22	NC	-	No connect

32	NC	-	No connect
33	GND	Ground	Power ground
34	NC	-	No connect
35	NC	-	No connect
36	NC	-	No connect
37, 38	NC	-	No connect
39	GND	Ground	Power ground
40, 41, 42, 43, 44	NC	-	No connect
45	GND	Ground	Power ground
46, 47, 48, 49	NC	-	No connect
50	SLOW_CLK_IN_3V3	I	External 32.768-KHz slow clock input, 3.3V level
51	GND	Ground	Power ground
52, 53, 54, 55	NC	-	No connect
56	nRESET_3V3	I	Reset line for enabling or disabling device (active low), 3.3V level
57	GND	Ground	Power ground
58, 59, 60, 61, 62	NC	-	No connect
63	GND	Ground	Power ground
64, 65, 66, 67, 68	NC	-	No connect
69	GND	Ground	Power ground
70, 71, 72, 73	NC	-	No connect
74	VDD_3V3	Power	3.3V power supply, 2.1V ~ 4.2V
75	GND	Ground	Power ground

4. Specifications

4.1. Absolute Maximum Ratings

Stresses beyond those listed under Absolute Maximum Ratings may cause permanent damage to the device. These are stress ratings only, so functional operation of the device at these or any other conditions beyond those indicated in the operational sections of the specification are not implied. Exposure to Absolute Maximum Rating conditions for extended periods may affect device reliability.

PARAMETER	MIN	MAX	UNIT	Notes
V _{DD_3V3}	TBD	TBD	V	
V _{DD_1V8}	TBD	TBD	V	
RF pin	TBD	TBD	dBm	
Storage Temperature	TBD	TBD	°C	

4.2. ESD Ratings

		VALUE	UNIT
V (ESD) Electrostatic discharge	Human-body model (HBM), per ANSI/ESDA/JEDEC JS-001 ⁽¹⁾	TBD	V
	Charged device model (CDM), per ANSI/ESDA/JEDEC JS-002 ⁽²⁾	TBD	

(1) JEDEC document JEP155 states that 500-V HBM allows safe manufacturing with a standard ESD control process.

(2) JEDEC document JEP157 states that 250-V CDM allows safe manufacturing with a standard ESD control process.

4.3 Recommended Operating Conditions

PARAMETER	MIN	TYP	MAX	UNIT	Notes
V _{DD_3V3}	2.1	3.3	4.2	V	
V _{DD_1V8}	1.62	1.8	1.98	V	
Storage Temperature	-40		85	°C	

5. Mechanical Specifications

5.1 Dimensions

Fig 5-1 and Fig 5-2 show the overall dimensions of the modules.

Note: All dimensions are in mm.

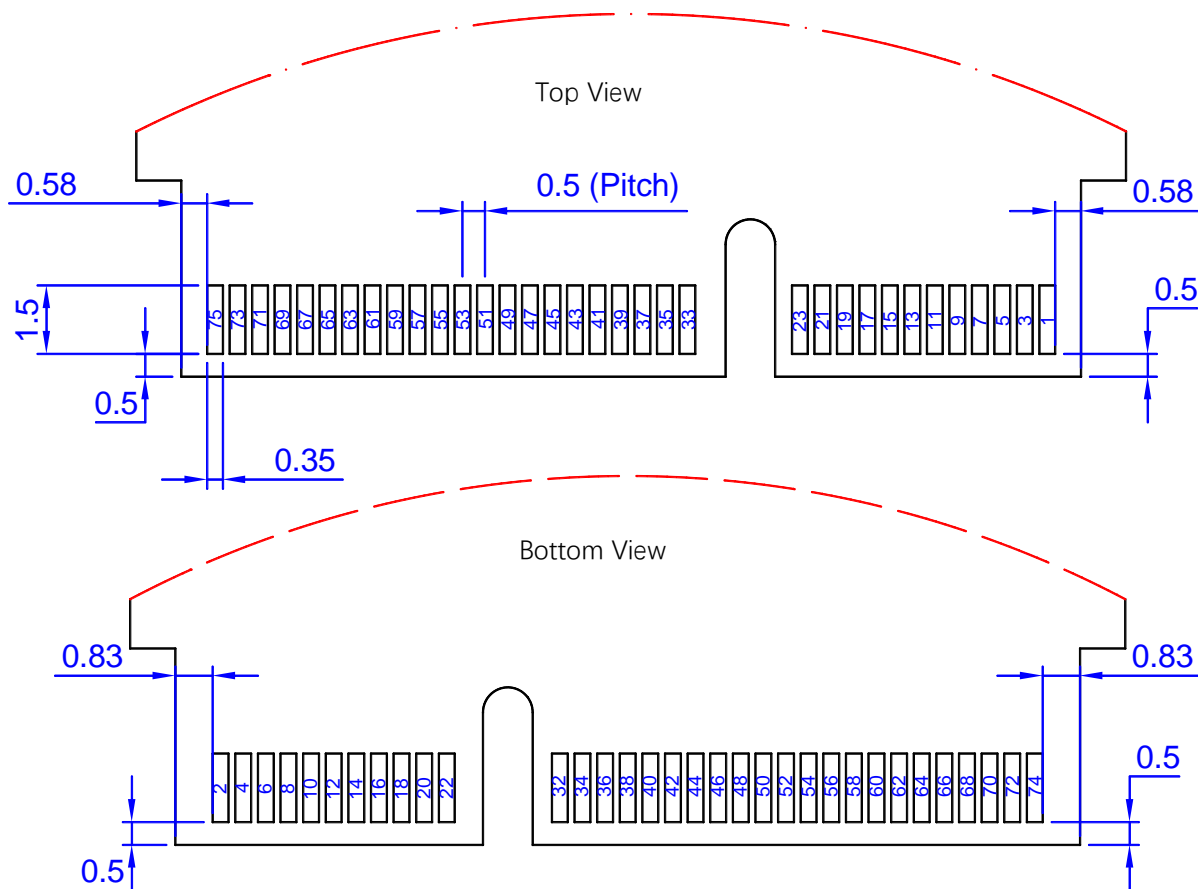
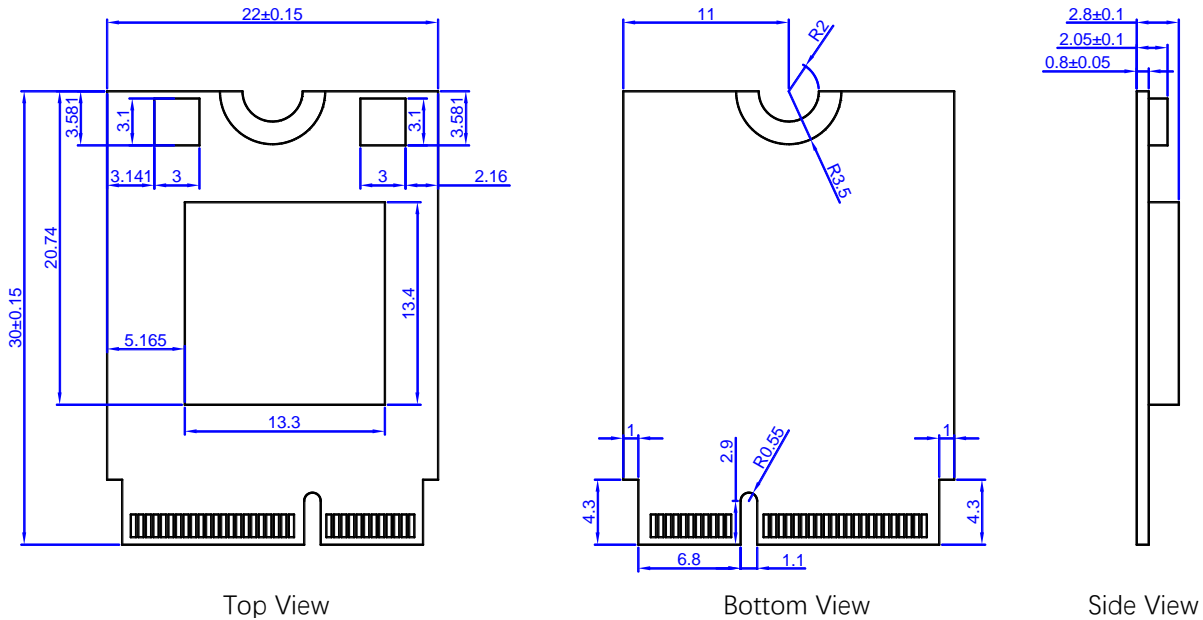
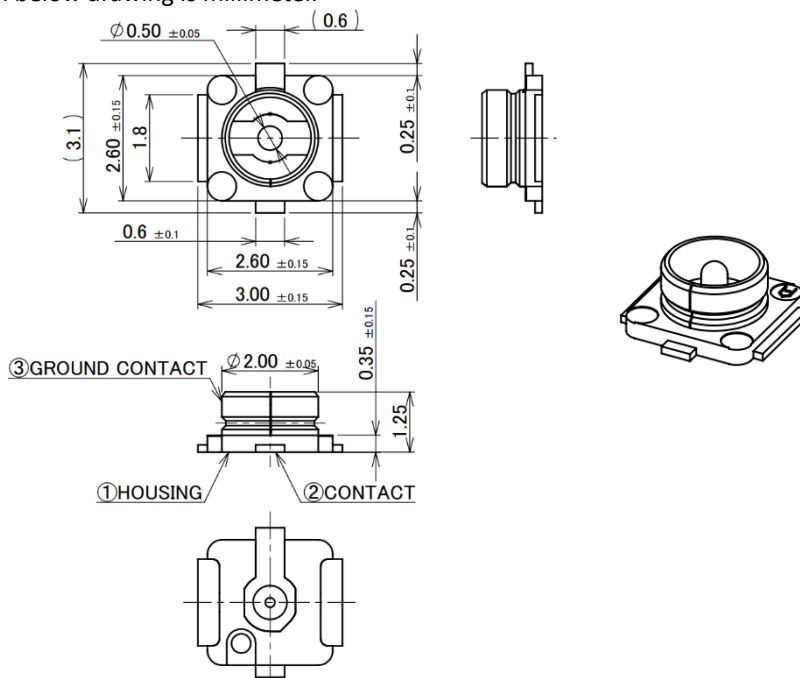

Figure 5-1. Mechanical Drawing of BDE-BW3300NPxM2

5.1 U.FL Connector Specification

The drawing and specification of the U.FL connector utilized in the card is as below for reference.

The dimension unit in below drawing is millimeter.



RATING VOLTAGE	60 V AC (R.M.S)	
RATING FREQUENCY	DC~9GHz	
OPERATING TEMPERATURE	233~363K (-40°C~+90°C)	
VSWR	RECEPTACLE: 1.3 MAX. AT 0.1~3 GHz, 1.4 MAX. AT 3~6 GHz, 1.8 MAX. AT 6~9 GHz	
MAIN CONTACT RESISTANCE	INITIAL: 20 mohm MAX. / AFTER TEST: Δ R 20 mohm MAX.	
GROUND CONTACT RESISTANCE	INITIAL: 20 mohm MAX. / AFTER TEST: Δ R 100 mohm MAX.	
INSULATION RESISTANCE	INITIAL: 500 Mohm MIN. / AFTER TEST: 100 Mohm MIN.	
DIELECTRIC WITHSTANDING VOLTAGE	200 V AC, 1 MINUTE	
DURABILITY	30 CYCLES	
UNMATING FORCE (INITIAL / AFTER TEST)	INITIAL: 5 N MIN. AFTER TEST: 3 N MIN.	INITIAL: 4 N MIN. AFTER TEST: 2 N MIN.

6. Reference Design

6.1 Block Diagram

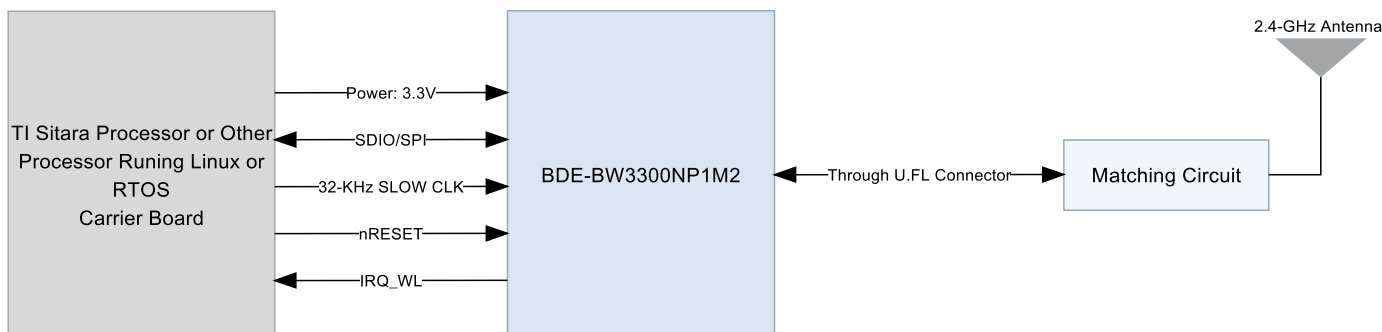

Note: Pin IRQ_WL is open drain output, pull-up resistors are needed in the carrier board.

Figure 6-1. High-Level System Block Diagram

6.2 Reference Schematic

For reference schematic, please refer to the [user guide](#) (Enable_BDE-BW3301NP1_with_AM62x_User_Guide) and [SK-AM62B](#) from TI.com.

6.3 Design Consideration

Below listed some of the design considerations while integrating the M.2 card to the system.

1. BDE recommends using double-shielded coaxial RF cable to connect with the U.FL connector with antenna;
2. Do not place or run the RF cable right above or below the card or module;
3. Consider the enclose materials. Do not place the antenna close to the metal;
4. Do not place high speed signal beneath the card;
5. If there are some other radio besides this card in the system, try to place them apart as far as possible. And Ensure there is at least 25 dB isolation between the antenna port of every radio;
6. Make VDD_3V3 traces as short as possible and as wide as possible to reduce the inductance and resistance of the traces, 40mil as least is recommended;
7. Proper decoupling capacitors are recommended for the card;
8. Proper ESD protection is recommended while installing the card to the host carrier board;
9. SDIO signals traces (CLK, CMD, DO, 01, 02, and 03) must be routed in parallel to each other and as short as possible (less than 12 cm). In addition, every trace length must be the same as the others. There should be enough space between traces- greater than 1.5 times the trace width or ground- to ensure signal quality, especially for the SDIO_CLK trace. Remember to keep these traces away from the other digital or analog signal traces. BDE recommends adding ground shielding around these buses;
10. SDIO and digital clock signals are a source of noise. Keep the traces of these signals as short as possible. If possible, maintain a clearance around them;

7. Ordering Information

Part Number	Description	Size (mm)	Core Chip	Shipping Form	MOQ
BDE-BW3300NP1M2	Wi-Fi 6 M.2 card, single antenna port	22 x 30 x 2.8	CC3300	TBD	TBD
BDE-BW3300NP2M2	Wi-Fi 6 M.2 card, dual antenna ports with antenna diversity without antenna	22 x 30 x 2.8	CC3300	TBD	TBD

8. Revision History

Revision	Date	Description
V0.1	28-Jul-2022	Preliminary, draft

You can find the latest documentation in this [Link](#).

Important Notice and Disclaimer

The information contained herein is believed to be reliable. BDE makes no warranties regarding the information contained herein. BDE assumes no responsibility or liability whatsoever for any of the information contained herein. BDE assumes no responsibility or liability whatsoever for the use of the information contained herein. The information contained herein is provided "AS IS, WHERE IS" and with all faults, and the entire risk associated with such information is entirely with the user. All information contained herein is subject to change without notice. Customers should obtain and verify the latest relevant information before placing orders for BDE products. The information contained herein or any use of such information does not grant, explicitly or implicitly, to any party any patent rights, licenses, or any other intellectual property rights, whether with regard to such information itself or anything described by such information.

Contact

BDE Technology Inc.

USA: 67 E Madison St, # 1603A, Chicago, IL 60603, US

Tel: +1-312-379-9589

Website: <http://www.bdecomm.com>

Email: info@bdecomm.com

China: B2-403, 162 Science Avenue, Huangpu District, Guangzhou 510663, China

Tel: +86-20-28065335

Website: <http://www.bdecomm.com>

Email: shu@bdecomm.com