

General Description

The WF3220 module, is a 802.11b/g/n, IPv4 & IPv6 Low Energy module based on CC3220S/F SoC.

The module offers a unique combination of lower power, integration of all external components including chip antenna at a very affordable cost.

Created for IoT , the WF3220 module is a wireless module that integrates two physically separated on-chip MCUs, application processor and network processor.

The WF3220 module is supported by easy to work with software to lower the threshold of using Wi-Fi technology or speeding up design time significantly.

The combination of affordable cost, lowest power and ease of use makes it an ideal product for the mass market, including the makers community.



Key Features

- Fully integrated and green and RoHS modules include all required clocks, SPI flash, and passives
- 802.11b/g/n: 2.4 GHz
- FIPS 140-2 Level 1 validated IC inside
- Multilayered security features help developers protect identities, data, and software IP
- Low-power modes for battery-powered applications
- Coexistence with 2.4-GHz radios
- Industrial temperature: -40°C to $+85^{\circ}\text{C}$
- WF3220 module includes a chip antenna for easy integration into the host system
- 1.27-mm pitch QFM package for easy assembly and low-cost PCB design
- Transferrable Wi-Fi Alliance® certification
- Application microcontroller subsystem:
 - Arm® Cortex®-M4 core at 80 MHz
 - User-dedicated memory:
 - 256KB of RAM
 - 1MB of executable flash
 - 4MB External Serial flash
 - Rich set of peripherals and timers:
 - McASP supports two I2S channels
 - SD, SPI, I2C, UART, ADC
 - 8-bit parallel interface
 - Timers and PWM
 - Watchdog timer
 - Up to 21 GPIO pins
- Debug interfaces: JTAG, cJTAG, SWD
- Wi-Fi network processor subsystem:
 - Wi-Fi® core:
 - 802.11 b/g/n
 - Modes:
 - 802.11b/g/n Station
 - 802.11b/g/n Access Point Supports up to Four Stations
 - Wi-Fi Direct® Client and Group Owner
 - Security:
 - WEP
 - WPA™/ WPA2™ PSK
 - WPA2 Enterprise
 - WPA3™ Personal
 - Internet and application protocols:
 - HTTPs server, mDNS, DNS-SD, DHCP
 - IPv4 and IPv6 TCP/IP stack
 - 16 BSD sockets (fully secured TLS v1.2 and SSL 3.0)
 - Built-in power management subsystem:
 - Configurable low-power profiles (always on, intermittently connected, tag)
 - Advanced low-power modes
 - Integrated DC/DC regulators
- Multilayered security features:
 - Separate execution environments
 - Networking security
 - Device identity and key
 - Hardware accelerator cryptographic engines(AES, DES, SHA/MD5, CRC)

- File system security (encryption, authentication, access control)
- Initial secure programming
- Software tamper detection
- Secure boot
- Certificate signing request (CSR)
- Unique per device key pair
- Application throughput
 - UDP: 16 Mbps
 - TCP: 13 Mbps
- Power-Management Subsystem:
 - Integrated DC/DC converters support a wide range of supply voltage:
 - Single wide-voltage supply VBAT: 2.3 V to 3.6 V
 - Advanced low-power modes:
 - Shutdown: 1 μ A, Hibernate: 5 μ A
 - Low-power deep sleep (LPDS): 135 μ A
 - Idle connected (MCU in LPDS): 710 μ A
- RX traffic (MCU active): 59 mA
- TX traffic (MCU active): 223 mA
- Wi-Fi TX power
 - 17 dBm at 1 DSSS
 - 13.5dBm at 54 OFDM
- Wi-Fi RX sensitivity
 - -95 dBm at 1 DSSS
 - -73.5 dBm at 54 OFDM
- Additional integrated components
 - 40.0-MHz crystal
 - 32.768-kHz crystal (RTC)
 - 32Mbit SPI serial flash(see [Device Family](#))
 - RF filters, diplexer and passive components
- Footprint-compatible QFM package
 - 1.27-mm pitch, 63-pin, 25mm \times 20.5mm \times 2.4mm
- Module supports the TI SimpleLink Developer's Ecosystem

Applications

- For Internet of Things applications, such as:
 - Medical and Healthcare
 - Multiparameter Patient Monitor
 - Electrocardiogram (ECG)
 - Electronic Hospital Bed & Bed Control
 - Telehealth Systems
 - Building and Home Automation:
 - HVAC Systems & Thermostat
 - Video Surveillance, Video Doorbells, and Low-Power Camera
 - Building Security Systems and E-locks
 - Appliances
 - Asset Tracking
 - Factory Automation
 - Grid Infrastructure

Device Family

Table 0-1. WF3220 Device Family

Part Number	Chipset	Description	Size (mm)	Package
WF3220SA32	CC3220S	With 32Mbit external flash, with PCB trace antenna	20.5 × 25 × 2.4	SMD-63
WF3220SAU32	CC3220S	With 32Mbit external flash, with U.FL connector for external antenna	20.5 × 25 × 2.4	SMD-63
WF3220SN32	CC3220S	With 32Mbit external flash, without antenna	20.5 × 17.5 × 2.4	SMD-63
WF3220SFA0	CC3220SF	Without external flash, with PCB trace antenna	20.5 × 25 × 2.4	SMD-63
WF3220SFAU0	CC3220SF	Without external flash, with U.FL connector for external antenna	20.5 × 25 × 2.4	SMD-63
WF3220SFA32	CC3220SF	With 32Mbit external flash, with PCB trace antenna	20.5 × 25 × 2.4	SMD-63
WF3220SFAU32	CC3220SF	With 32Mbit external flash, with U.FL connector for external antenna	20.5 × 25 × 2.4	SMD-63
WF3220SFN0	CC3220SF	Without external flash, without antenna	20.5 × 17.5 × 2.4	SMD-63
WF3220SFN32	CC3220SF	With 32Mbit external flash, without antenna	20.5 × 17.5 × 2.4	SMD-63

Contents

General Description	1
Key Features.....	1
Applications	2
Device Family	3
Contents.....	4
1. References.....	5
2. Block Diagram	6
3. Terminal Configuration and Functions.....	7
3.1 Pin Diagram.....	7
3.2 Pin Attributes and Pin Multiplexing	7
3.3 Connections for Unused Pins	10
4. Specifications	11
4.1 Absolute Maximum Ratings	11
4.2 Recommended Operating Conditions.....	11
5. Mechanical Specifications.....	12
5.1 Dimensions.....	12
5.2 PCB Footprint	13
5.3 Marking.....	错误!未定义书签。
6. Ordering Information	14
7. Revision History	14

1. References

- [1] CC3220S resources: <https://www.ti.com/product/CC3220S>
- [2] CC3220SF resources: <https://www.ti.com/product/CC3220SF>
- [3] CC3220MODA resources: <https://www.ti.com/product/CC3220MODA>

2. Block Diagram

WF3220 module is based on the TI Instruments CC3220S/F SoC. With an integrated 32Mbit flash, 40MHz XTAL and a dual band chip antenna or an U.FL connector, it allows faster time to market at reduced development cost.

The module, as seen in Figure 1, comprises of:

- 32 Mbit SPI Flash
- 40MHz XTAL
- 32.768kHz XTAL
- a filters
- a dual band chip antenna(only in A series) or an U.FL connector(only in AU series)

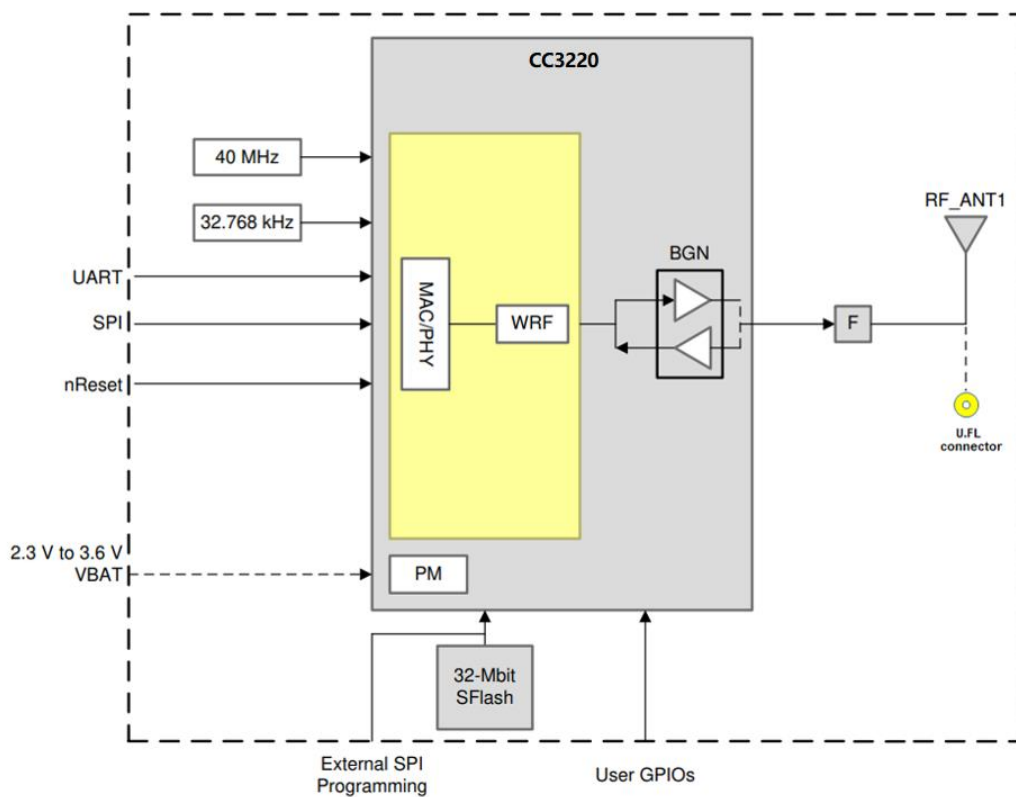

Figure 2-1. WF3220 Module Block Diagram

3. Terminal Configuration and Functions

3.1 Pin Diagram

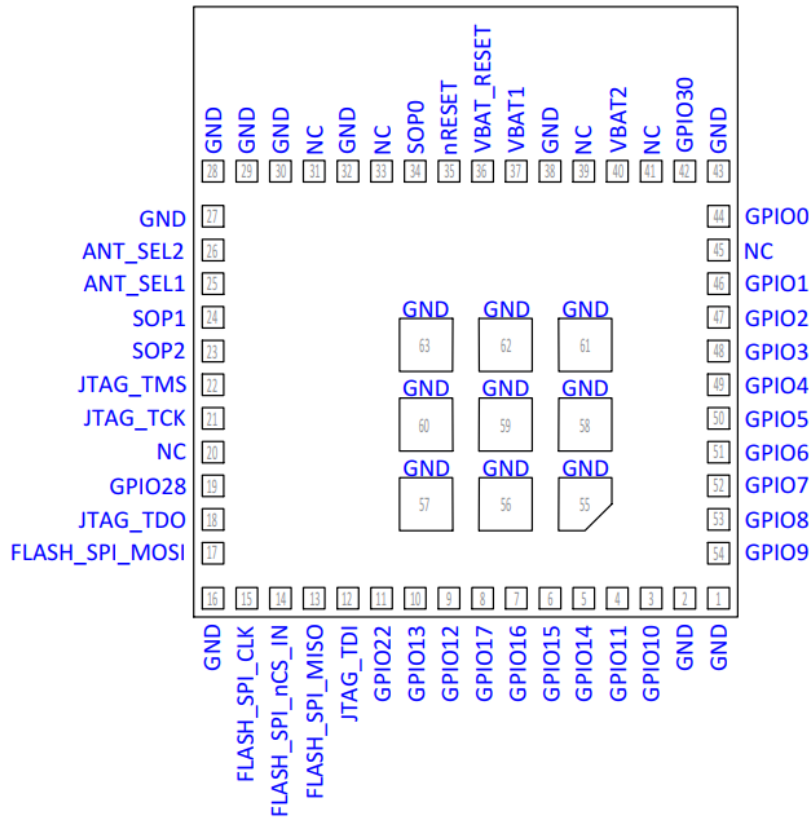

Figure 3-1. Pin Diagram Bottom View

3.2 Pin Attributes and Pin Multiplexing

Table 3-1. Pin Description

Pin #	Pin Name	Type ⁽¹⁾	Description
1	GND	–	Ground
2	GND	–	Ground
3	GPIO10	I/O	GPIO
4	GPIO11	I/O	GPIO
5	GPIO14	I/O	GPIO
6	GPIO15	I/O	GPIO
7	GPIO16	I/O	GPIO
8	GPIO17	I/O	GPIO
9	GPIO12	I/O	GPIO
10	GPIO13	I/O	GPIO
11	GPIO22	I/O	GPIO
12	JTAG_TDI	I/O	JTAG TDI input. Leave unconnected if not used on product

Pin #	Pin Name	Type ⁽¹⁾	Description
13	FLASH_SPI_MISO	I	External serial flash programming: SPI data in
14	FLASH_SPI_nCS_IN	I	External serial flash programming: SPI chip select (active low)
15	FLASH_SPI_CLK	I	External serial flash programming: SPI clock
16	GND	–	Ground
17	FLASH_SPI_MOSI	O	External serial flash programming: SPI data out
18	JTAG_TDO	I/O	JTAG TDO output. Leave unconnected if not used on product ⁽¹⁾
19	GPIO28	I/O	GPIO
20	NC	–	No Connect
21	JTAG_TCK	I/O	JTAG TCK input. Leave unconnected if not used on product. An internal 100-k Ω pull-down resistor is tied to this pin.
22	JTAG_TMS	I/O	JTAG TMS input. Leave unconnected if not used on product.
23	SOP2	–	An internal 100-k Ω pull-down resistor is tied to this SOP pin. An external 10-k Ω resistor is required to pull this pin high.
24	SOP1	–	An internal 100-k Ω pull-down resistor is tied to this SOP pin. An external 10-k Ω resistor is required to pull this pin high.
25	ANT_SEL1	I/O	Antenna selection control
26	ANT_SEL2	I/O	Antenna selection control
27	GND	–	Ground
28	GND	–	Ground
29	GND	–	Ground
30	GND	–	Ground
31	NC	–	No Connect
32	GND	–	Ground
33	NC	–	No Connect
34	SOP0	–	An internal 100-k Ω pull-down resistor is tied to this SOP pin. An external 10-k Ω resistor is required to pull this pin high.
35	nRESET	I	<p>There is an internal, 100-kΩ pullup resistor option from the nRESET pin to VBAT_RESET. Note: VBAT_RESET is not connected to VBAT1 or VBAT2 within the module. The following connection schemes are recommended:</p> <ul style="list-style-type: none"> • Connect nRESET to a switch, external controller, or host, only if nRESET will be in a defined state under all operating conditions. Leave VBAT_RESET unconnected to save power. • If nRESET cannot be in a defined state under all operating conditions, connect VBAT_RESET to the main module power supply (VBAT1 and VBAT2). Due to the internal pullup resistor a leakage current of 3.3 V / 100 kΩ is expected.
36	VBAT_RESET	–	
37	VBAT1	Power	Power supply for the module, must be connected to battery (2.3 V to 3.6 V)
38	GND	–	Ground
39	NC	–	No Connect
40	VBAT2	Power	Power supply for the module, must be connected to battery (2.3 V to 3.6 V)
41	NC	–	No Connect
42	GPIO30	I/O	GPIO
43	GND	–	Ground

Pin #	Pin Name	Type ⁽¹⁾	Description
44	GPIO0	I/O	GPIO
45	NC	–	No Connect
46	GPIO1	I/O	GPIO
47	GPIO2	I/O	GPIO
48	GPIO3	I/O	GPIO
49	GPIO4	I/O	GPIO
50	GPIO5	I/O	GPIO
51	GPIO6	I/O	GPIO
52	GPIO7	I/O	GPIO
53	GPIO8	I/O	GPIO
54	GPIO9	I/O	GPIO
55	GND	–	Thermal ground
56	GND	–	Thermal ground
57	GND	–	Thermal ground
58	GND	–	Thermal ground
59	GND	–	Thermal ground
60	GND	–	Thermal ground
61	GND	–	Thermal ground
62	GND	–	Thermal ground
63	GND	–	Thermal ground

(1) I = input; O = output; I/O = bidirectional

The module makes extensive use of pin multiplexing to accommodate the large number of peripheral functions in the smallest possible package. To achieve this configuration, pin multiplexing is controlled using a combination of hardware configuration (at module reset) and register control.

The board and software designers are responsible for the proper pin multiplexing configuration. Hardware does not ensure that the proper pin multiplexing options are selected for the peripherals or interface mode used.

3.3 Connections for Unused Pins

All unused pin should be configured as stated in [Table 3-2](#).

Table 3-2. Connections for Unused Pins

FUNCTION	SIGNAL DESCRIPTION	PIN NUMBER	ACCEPTABLE PRACTICE
GPIO	General-purpose input or output		Wake up I/O source should not be floating during hibernate. All the I/O pins will float while in Hibernate and Reset states. Ensure pullup and pulldown resistors are available on board to maintain the state of the I/O. Leave unused GPIOs as NC
No Connect	NC	20, 31, 33, 39, 41, 45	Unused pin, leave as NC.
SOP	Configuration sense-on-power	23, 24, 34	Leave as NC (Modules contain internal 100-k Ω pulldown resistors on the SOP lines). An external 10-k Ω pullup resistor is required to pull these pins high.
Reset	RESET input for the device		Never leave the reset pin floating
JTAG	JTAG interface		Leave as NC if unused

4. Specifications

All measurements are referenced at the module pins unless otherwise indicated. All specifications are over process and voltage unless otherwise indicated.

Over operating free-air temperature range (unless otherwise noted)^{(1) (2)}

4.1 Absolute Maximum Ratings

Table 4-1. Absolute Maximum Ratings

PARAMETER	MIN	MAX	UNIT
V _{BAT}	-0.5	3.8	V
Digital I/O	-0.5	V _{BAT} + 0.5	V
Analog pins	-0.5	2.1	V
Operating temperature (T _A)	-40	85	°C
Storage temperature (T _{stg})	-40	120	°C

(1) Stresses beyond those listed under *Absolute Maximum Ratings* may cause permanent damage to the device. These are stress ratings only, and functional operation of the device at these or any other conditions beyond those indicated under *Recommended Operating Conditions* is not implied. Exposure to absolute-maximum-rated conditions for extended periods may affect device reliability.

(2) All voltage values are with respect to V_{SS}, unless otherwise noted.

4.2 Recommended Operating Conditions

Over operating free-air temperature range (unless otherwise noted)^{(2) (1) (3)}

PARAMETER	MIN	TYP	MAX	UNIT
V _{BAT}	2.1	3.3	3.6	V
Operating temperature	-40	25	85	°C
Ambient thermal slew	-20		20	°C/minute

(1) When operating at an ambient temperature of over 75°C, the transmit duty cycle must remain below 50% to avoid the auto-protect feature of the power amplifier. If the auto-protect feature triggers, the device takes a maximum of 60 seconds to restart the transmission.

(2) To ensure WLAN performance, the ripple on the power supply must be less than ±300 mV. The ripple should not cause the supply to fall below the brownout voltage.

(3) The minimum voltage specified includes the ripple on the supply voltage and all other transient dips. The brownout condition is also 2.1 V, and care must be taken when operating at the minimum specified voltage.

5. Mechanical Specifications

5.1 Dimensions

The module dimensions are presented in the following figure:

Note: All dimensions are in mm

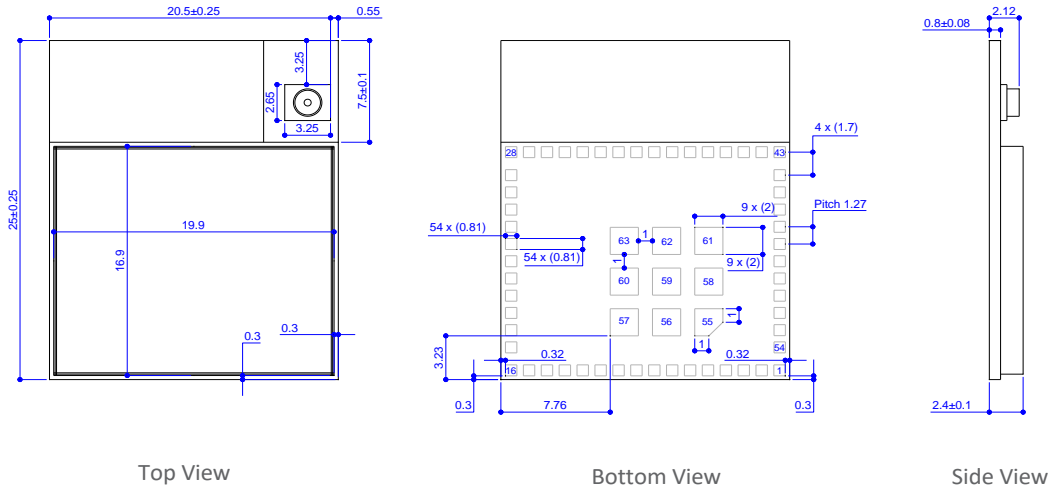

Figure 5-1: Mechanical Drawing

5.2 PCB Footprint

The footprint for the PCB is presented in the following figure:

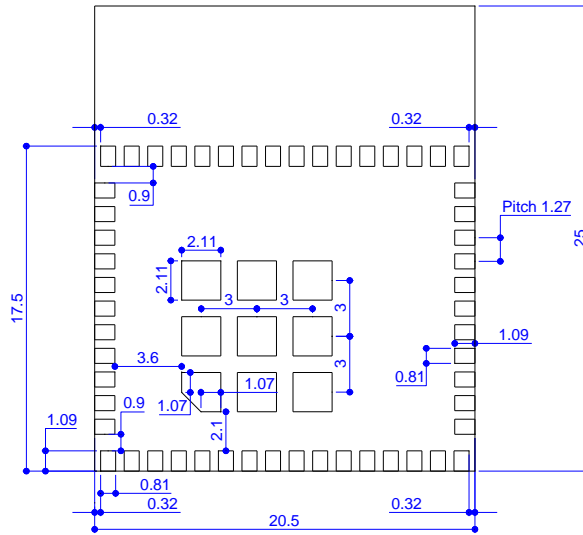

Figure 5-2: Module Footprint Top View

Ordering Information
Table 6-1: Ordering Information

Part Number	Size (mm)	Shipping Form	MOQ
WF3220SA32	20.5 × 25 × 2.4	Tape & Reel	1000
WF3220SAU32	20.5 × 25 × 2.4	Tape & Reel	1000
WF3220SN32	20.5 × 17.5 × 2.4	Tape & Reel	1000
WF3220SFA0	20.5 × 25 × 2.4	Tape & Reel	1000
WF3220SFAU0	20.5 × 25 × 2.4	Tape & Reel	1000
WF3220SFA32	20.5 × 25 × 2.4	Tape & Reel	1000
WF3220SFAU32	20.5 × 25 × 2.4	Tape & Reel	1000
WF3220SFN0	20.5 × 17.5 × 2.4	Tape & Reel	1000
WF3220SFN32	20.5 × 17.5 × 2.4	Tape & Reel	1000

6. Revision History

Revision	Date	Description
V1.0	15-Jun-2021	Initial Released
V2.1	29-Aug-2023	Picture, Size

Contacts

BDE Technology Inc.

USA: 67 E Madison St, # 1603A, Chicago, IL 60603, US

Tel: +1-312-379-9589

Website: <http://www.bdecomm.com> Email: info@bdecomm.com

China: B2-403, 162 Science Avenue, Huangpu District, Guangzhou 510663, China

Tel: +86-20-28065335

Website: <http://www.bdecomm.com> Email: sales@bdecomm.com