

## General Description

BDE-BD2564CA is a Bluetooth 5.1 BR/EDR & LE dual mode transceiver module.

The module integrates Bluetooth classic and Bluetooth Low Energy radio TI's CC2564C, a 26-MHz crystal oscillator, a band pass filter, a fine-tuned chip antenna and all the passive components at a very affordable cost.



The module provides the best-in-class RF performance with transmit power and receive sensitivity that provides twice the range and higher throughput than other Bluetooth-low-energy-only solutions. The power-management hardware and software algorithms provide significant power savings in all commonly used Bluetooth BR/EDR and low energy modes of operation.

The certified and royalty free Dual-mode Bluetooth 5.1 protocol stack software provides a complete Bluetooth BR/EDR, and Bluetooth Low Energy sample applications that reduce design effort and ensure a faster time to market.

The module has a very small form factor with the dimensions of 7 mm x 14 mm x 1.55 mm.

## Key Features

- Bluetooth 5.1 dual mode
  - Bluetooth Basic Rate (BR)
  - Enhanced Data Rate (EDR)
  - Low Energy (LE)
- BR and EDR features include:
  - Up to seven active devices
  - Scatternet: Up to three piconets simultaneously, one as master and two as slaves
  - Up to two Synchronous Connection Oriented (SCO) links on the same piconet
  - Support for all voice air-coding – continuously Variable Slope Delta (CVSD), A-Law,  $\mu$ -Law, modified Subband Coding (mSBC), and transparent (Uncoded)
  - Provide an assisted mode for HFP 1.6 Wideband Speech (WBS) profile or A2DP profile to reduce host processing and power
  - Support of multiple Bluetooth profiles with enhanced QoS
- Low Energy features include:
  - Multiple sniff instances tightly coupled to achieve minimum power consumption
  - Independent buffering for Low Energy allows large numbers of multiple connections without affecting BR or EDR performance
- Built-In coexistence and prioritization handling for BR, EDR, and Low Energy
- Capabilities of link layer topology, Scatternet - can act concurrently as peripheral and central
- Network support for up to 10 devices
- Time line optimization algorithms to achieve maximum channel utilization
- Best-in-Class Bluetooth (RF) performance (TX power, RX sensitivity, blocking)
  - TX power up to +8 dBm
  - Internal temperature detection and compensation to ensure minimal variation in RF performance over temperature, no external calibration required
  - Improved Adaptive Frequency Hopping (AFH)
  - Algorithm with minimum adaptation time
  - Longer range, including twice the range of other Low-Energy-Only solutions
- Advanced power management for extended battery life and ease of design
  - On-Chip power management, including direct connection to battery
  - Low power consumption for active, standby, and scan Bluetooth modes
  - Shutdown and sleep modes to minimize power

- consumption
- Physical interfaces:
  - UART Interface with support for maximum Bluetooth data rates
  - UART transport layer (H4) with maximum rate of 4 Mbps
  - Three-Wire UART transport layer (H5) with maximum rate of 4 Mbps
  - Fully programmable Digital Pulse-Code Modulation (PCM) - I2S codec interface
- Flexibility for easy stack integration and validation into MCUs and MPUs
- HCI tester tool to evaluate RF performance of the device and configure service pack
- Antenna: chip antenna, 0.5 dBi gain
- Size: 7 mm x 14 mm x 1.55 mm (With Shield)
- Standards Conformance
  - *Bluetooth*® SIG
  - CE-RED (Europe)
  - FCC (US)
  - ISED (Canada)
  - Japan (Telec)

## Applications

- Mobile Accessories
- Sports and Fitness Applications
- Wireless Audio Solutions
- Set-Top Boxes and Remote Controls
- Toys
- Test and Measurement
- Industrial: Cable Replacement
- Wireless Sensors
- Automotive Aftermarket
- Wellness and Health

## Contents

General Description .....	1
Key Features.....	1
Applications .....	3
Contents.....	4
1. Block Diagram.....	5
2. Pinout .....	6
3. Characteristics .....	7
3.1. Absolute Maximum Ratings .....	7
3.2. Recommended Operating Conditions.....	8
4. Mechanical Specifications .....	9
4.1. Dimensions .....	9
5.1. PCB Footprint .....	10
5. Marking .....	10
6. Ordering Information .....	11
7. Revision History .....	11
Contacts .....	11

### 1. Block Diagram

BDE-BD2564CA integrates Bluetooth classic and Bluetooth Low Energy radio TI's CC2564C, a 26-MHz crystal oscillator, a band pass filter, a fine-tuned chip antenna and all the passive components at a very affordable cost. Figure 1-1 shows the block diagram of the module.

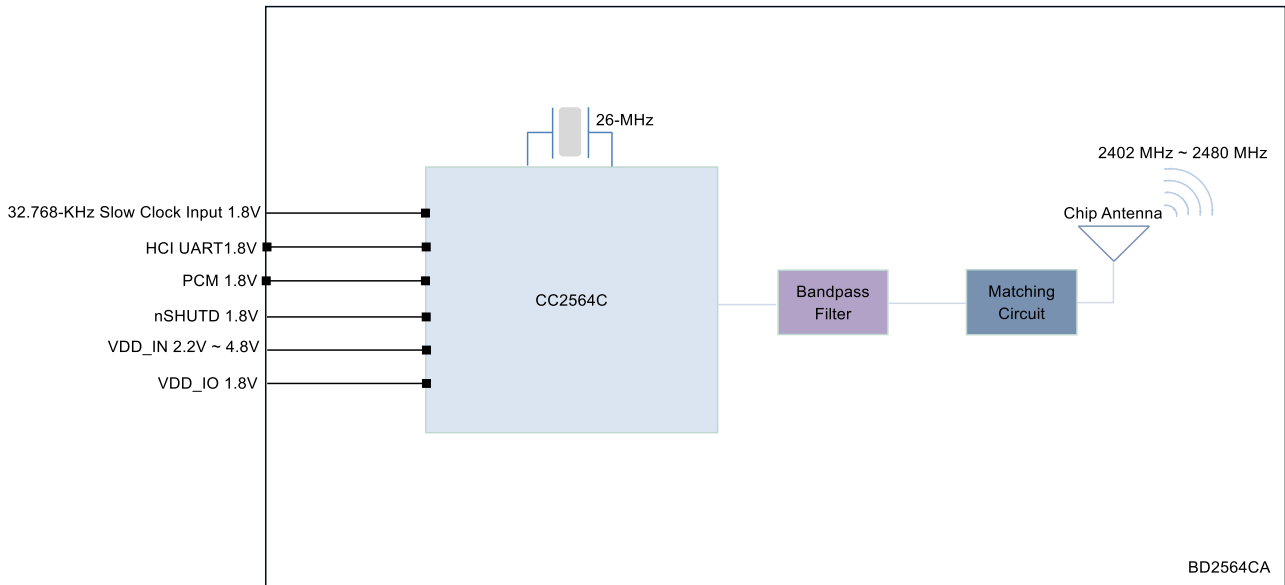
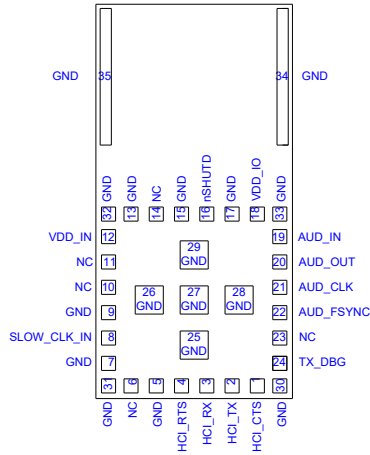

Figure 1-1. The block diagram of BDE-BD2564CA

## 2. Pinout



Bottom View

Figure 2-1. Pinout Diagram Bottom View

Table 2-1 describes the definitions of the pins.

Table 2-1. Pin Description

Pin #	Pin Name	Type	Description
1	HCI_CTS	DI <sup>(Note 1)</sup> , pU <sup>(Note 2)</sup>	HCI UART clear-to-send. The device can send data when HCI_CTS is low
2	HCI_TX	DO, PU	HCI UART data transmit
3	HCI_RX	DI, PU	HCI UART data receive
4	HCI_RTS	DO, PU	HCI UART request-to-send. Host can send data when HCI_RTS is low
5	GND	GND	Power ground
6	NC	-	Not connected
7	GND	GND	Power ground
8	SLOW_CLK_IN	DI	32.768-kHz clock in, fail-safe
9	GND	GND	Power ground
10	NC	-	Not connected
11	NC	-	Not connected
12	VDD_IN	Power	Main power supply for the module (2.2 to 4.8 V)
13	GND	GND	Power ground
14	NC	-	Not connected
15	GND	GND	Power ground
16	nSHUTD	DI, PD	Shutdown input (active low)
17	GND	GND	Power ground
18	VDD_IO	Power	I/O power supply (1.8 V nominal)
19	AUD_IN	DI, PD	PCM data input, fail-safe
20	AUD_OUT	DO, PD	PCM data output, fail-safe
21	AUD_CLK	DIO <sup>(Note 1)</sup> , PD	PCM clock, fail-safe

Pin #	Pin Name	Type	Description
22	AUD_FSYNC	DIO, PD	PCM frame sync, fail-safe
23	NC	-	Not connected
24	TX_DBG	DO, PU	Internal debug messages
25	GND	GND	Power ground
26	GND	GND	Power ground
27	GND	GND	Power ground
28	GND	GND	Power ground
29	GND	GND	Power ground
30	GND	GND	Power ground
31	GND	GND	Power ground
32	GND	GND	Power ground
33	GND	GND	Power ground

Note 1: DI stands for Digital Input, DO stands for Digital Output, DIO stands for Digital Input-Output;

Note 2: PU stands for internal Pull-Up, PD stands for internal Pull-Down.

### 3. Characteristics

All MIN/MAX specification limits are guaranteed by design, production testing and/or statistical characterization. Typical values are based on characterization results at default measurement conditions and are informative only.

Default measurement conditions (unless otherwise specified): VDD\_IN = 3.6 V, VDD\_IO = 1.8V, TA = 25 °C. All radio measurements are performed with standard RF measurement equipment.

#### 3.1. Absolute Maximum Ratings

Stresses beyond those listed under Absolute Maximum Ratings may cause permanent damage to the device. These are stress ratings only, so functional operation of the device at these or any other conditions beyond those indicated in the operational sections of the specification are not implied. Exposure to Absolute Maximum Rating conditions for extended periods may affect device reliability.

**Table 3-1. Absolute Maximum Ratings**

PARAMETER	MIN	MAX	UNIT	Notes
VDD_IN	-0.5	4.8	V	
VDD_IO	-0.5	2.415	V	
Input voltage to analog pin	-0.5	2.1	V	BT_ANT
Input voltage to all other pins	-0.5	VDD_IO + 0.5		
Bluetooth RF pin		10	dBm	
Storage Temperature	-40	100	°C	

### 3.2. Recommended Operating Conditions

**Table 3-2. Recommended Operating Conditions**

PARAMETER	MIN	TYP	MAX	UNIT
VDD_IN	2.2		4.8	V
VDD_IO	1.62		1.92	V
Operating Temperature	-40	-	85	°C



## 4. Mechanical Specifications

### 4.1. Dimensions

The module dimensions are presented in the following figure:

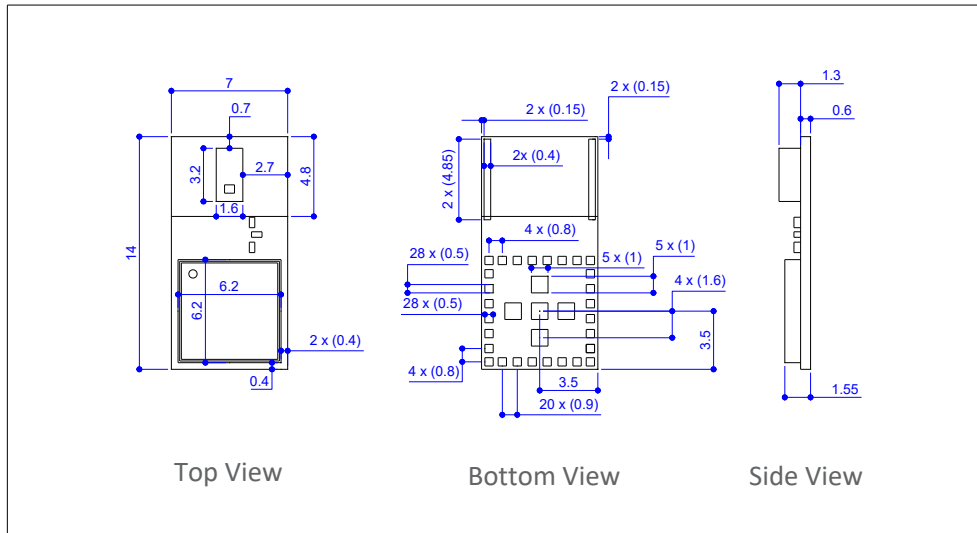

Note: All dimensions are in millimeter

Figure 4-1. Mechanical Drawing

### 4.2. PCB Footprint

The footprint for the PCB is presented in the following figure:

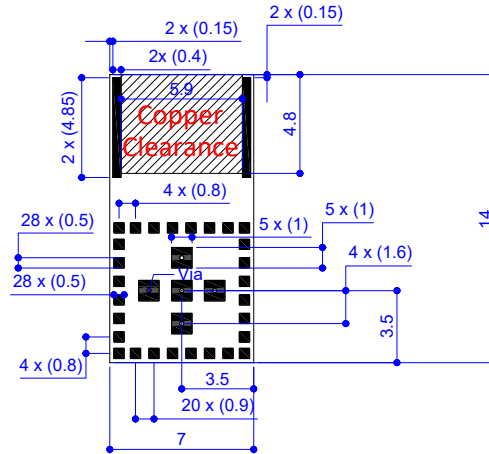

Note: All dimensions are in millimeter

Figure 4-2. Module Footprint Top View

### 5. Marking

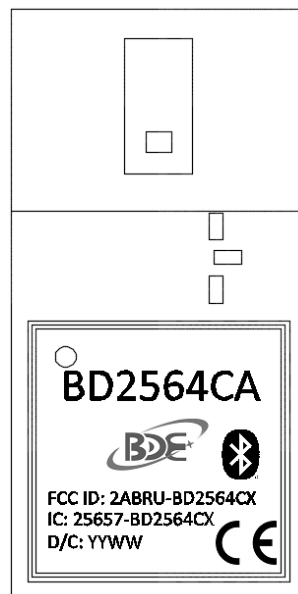

Figure 5-1. Module Marking

## 6. Ordering Information

Part Number	Description	Size (mm)	Package	MOQ
BDE-BD2564CA	Bluetooth 5.1 Dual Mode Transceiver Module	7 × 14 × 1.55	Tape & Reel	1000

## 7. Revision History

Revision	Date	Description
V1.0	17-July-2021	Initial Release, brief
V2.0	27-Dec-2021	Change Module's name

## Contacts

### BDE Technology Inc.

**USA:** 67 E Madison St, # 1603A, Chicago, IL 60603, US

Tel: +1-312-379-9589

Website: <http://www.bdecomm.com>

Email: [info@bdecomm.com](mailto:info@bdecomm.com)

**China:** B2-403, 162 Science Avenue, Huangpu District, Guangzhou 510663, China

Tel: +86-20-28065335

Website: <http://www.bdecomm.com>

Email: [sales@bdecomm.com](mailto:sales@bdecomm.com)